

## SECTION 7 INDEX

*The number in brackets indicates page number the product is on*

### **A-1 Security**

---

CapSaver Press [2]

---

Mean Green Machine [2]

---

### **HPC**

---

Blue Shark™ [7]

---

CodeMax™ [7]

---

CodeSource™ [8]

---

Cutters [11-12]

---

Duplicators [4]

---

Key Marking Devices [3]

---

KeyTrail™ [9]

---

MasterKing™ [10]

---

Parts/Accessories [13]

---

Punches [5-6]

---

Punch Machines [6]

---

### **Kaba Ilco**

---

Key Machines [13]

---

Parts/Accessories [13]

---

### **Numberall**

---

Key Stamping Machine [14]

---

### **Pro Lok**

---

Code Key Machine [14]

---

**Fairway**

DALLAS • HOUSTON • AUSTIN • NASHVILLE

**THE SECURITY PROFESSIONAL SUPPLIER**



## CAPSAVER PRESS

A revolutionary timesaver for capping I/Core. A-1's innovative process eliminates the need for caps which results in tremendous time saving since there is not need to place 6 or 7 caps. Caps are formed from a brass strip as you seat them into the core.



CAP-5	CapSaver Press
CS-50	CapSaver strips box of 50
CS-250	CapSaver strips, box of 250

## MEAN GREEN MACHINE

The Mean Green Machine is fast, accurate and more versatile than the Original Best® key combinator. It features interchangeable vices allowing you to quickly switch punching capability from SFIC to other specialty keyways. Because I/Core demands tighter tolerances, the Mean Green Machine is designed to be accurate as possible. The side mounted depth knob and automatic key advance speed up the cutting process without miscuts. Manufactured with cast iron and brass, A-1's Mean Green Machine is built to last.



GP201-A2	Mean Green Machine for system A2
GP201-A3	Mean Green Machine for system A3
GP201-A4	Mean Green Machine for system A4
GP201-FA2	Mean Green Machine for Flexcore



## KEY MARKING DEVICES

### STAMP ALIGNER™

The Stamp Aligner™ holds the stamps so that figures may be stamped on keys in an exact straight line with exact spacing between characters.

A key is placed onto the bottom part of the Stamp Aligner and secured in place. The top part is moved into one of the spacing indexes. The stamp is placed into the square hole over the spot where the key is to be stamped. The stamp is held exactly in place for it to be struck by a hammer. Spacing is clearly defined by a spring loaded detent built into the device. Each character stamped on the key will be straight, spaced evenly, and aligned perfectly. When the stamps are all struck with the same force, the result is a key that looks like it was factory stamped. Hammer not included. SA7 1/4" square hole fits 3/32" and 1/8" number and letter die stamps (stamps not included).

**SA7**

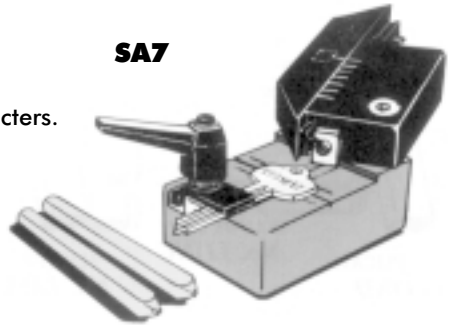

HPC SA7

Stamp Aligner

### SPECIALTY LOCKSMITH STAMPS

Permanently mark master or restricted keys with these specialty stamps. Made of heavy duty steel stock, 3/8" x 5/8" with 1/16" characters, hardened and flash-chromed for years of trouble free service.



HPC LDND Stamp "Do Not Duplicate"

### HAND-CUT DIE STAMP SETS

- ▶ Tempered head prevents mushrooming
- ▶ Extra tough shank prevents bending
- ▶ Hand ground taper makes locating easier
- ▶ Specially hardened character end prevents chipping
- ▶ Index on thumb side prevents stamping upside-down
- ▶ Sharp chisel edge character face assures clear impressions
- ▶ Chrome plated
- ▶ Plastic box

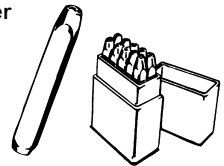

#### Figure Sets:

HPC HCF1/8	1/8" Number Stamp
HPC HCF3/32	3/32" Number Stamp

#### Letter Sets:

HPC HCL1/8	1/8" Letter Stamp
HPC HCL3/32	3/32" Standard Letter Stamp

**For current pricing, call your Fairway Representative today!**

**Dallas 800.776.3247 • Houston 800.767.3247 • Austin 877.309.6300 • Nashville 800.815.3247**



## MINI SPEEDEX®

### LIGHTWEIGHT KEY DUPLICATOR

The most accurate small key machine on the market. Has 4-way jaws which allow a wide variety of key cuts. Cut regular or large-bow keys (Flat steel and safe deposit box keys can be cut with optional cutter kit - CW16KIT). Comes with HPC Soffie rotary brush. Durable construction and bronze bearing. 120 V AC 1/10H.P., 1.5 Amps. Wt. 16 lbs. With CW 23RM cutter. Shipping Wt: 16 lbs. Machine Size: 11"W x 8"D x 8"H.

Bench Size: 16"W x 11"D

HPC 9120RM Key Machine Mini Speedex

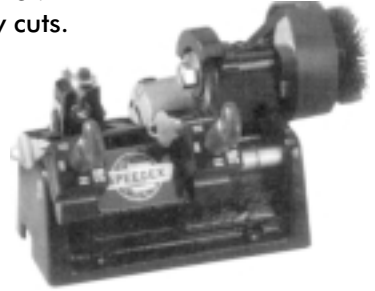

## PREMIER SPEEDIX®

### MANUAL KEY DUPLICATOR

Perfect for the largest of keys, hotel/motel room keys. Equipped with 4-way jaws. Reversible copy dog allows you to cut flat steel keys with optional slotting cutter kit (CW-16KIT). Mounted on a sturdy base and equipped with a heavy-duty motor. Steel construction and bronze bearings. 120V AC 1/6 HP, 3.5 Amps. Weight: 30 lbs. With CW-23MC Cutter. Machine Size: 12"W x 14" D x 8" H

HPC 9160MC

Key Machine

HPC 9120 BELT

Belt for 9120 Key Machine



## POWER SPEEDIX®

### SEMI-AUTOMATIC KEY DUPLICATOR WITH COVER

All the features of the Premier Speedex, plus it is operated by a spring-loaded lever. The carriage moves smoothly with the use of one hand when cutting keys. Also has a molded plastic vocer with a built-in light that encloses the motor. Designed to cut large bow keys and has 4-way jaws for cutting double sided keys. Mounted on a sturdy base and equipped with the HPC Soffie rotary brush. Durable construction and bronze bearings. 120V AC 1/6 HP, 3.5 amps. CW-23MC Cutter supplied. Machine size: 13"W x 16" D x 10" H. Bench Size: 18"W x 19"D.

HPC 9180MC Power Speedex Semi-Auto





## THE BLITZ™

The Blitz™ (1200CMB) is an upgraded version of the 1200CM. It works exactly the same as the 1200CM, but has several added features. Both the depth and spacing cranks have fewer threads per inch, which means that less revolutions are needed to achieve the full range of travel. Additional features include a new flip-gauge that is more visible and easier to grasp. The top of the gauge is made of a red anodized aluminum, so that when the gauge is up, it serves as a red flag. Plus, the Blitz machine is equipped with HPC's Sofie™ deburring brush with a safety shield.

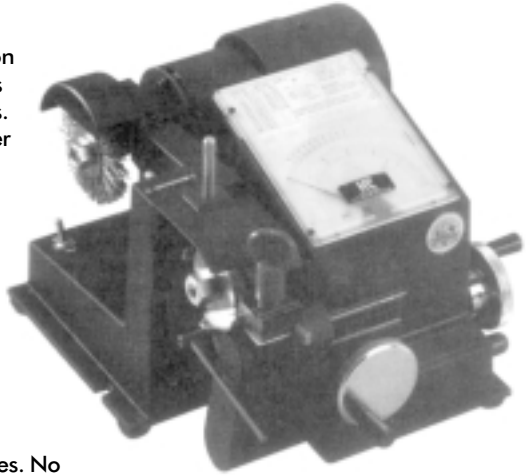

Cuts by actual manufacturer's depths & spaces. No need to convert to micrometer readings. With its rotating cutter head, the Blitz can cut Medeco keys (including Biaxial).

The ease of changing from one manufacturer's specs to another's is simple. Even radically different changes can be set up in 10 - 30 seconds without wasting keyblanks.

Code cards are inserted in the code machine. These cards contain all of the pertinent information. Depth and space adjustments are never required when changing from one manufacturer to another. A must for those who create master key systems or do code work.

With its decreased time between cuts and other added features, the Blitz™ is destined to become the new "Standard of the Industry"!

## THE 1200CMB CUTS STANDARD MEDECO KEYS

This Medeco® Jaw enable you to cut Medeco® level 1 commercial keys. This jaw is for use with the 1200CMB Code Machines and CodeMax™.



HPC MJ1

Medeco Jaw

120 VAC, 1/6 HP, 3.5 amps.

Weight: 30 lbs.

Cutters Supplied: CW-14MC, CW-1011

Machine Size: 12"W x 14"D x 9"H

Bench Size: 20"W x 14"D

### Accessories Included:

- Code Cards (112 code cards/ 8 micrometer cards)
- Brass Shim on Chain
- Horseshoe Tip Stop
- Binder (for 120 cards) with Manual
- Depth Adjustment/Cutter Wrench
- Space Adjustment Wrench
- Cutter Nut Wrench
- Replacement Tip Stop
- Manual

HPC 1200CMB

Code Machine Blitz

## 1200CM SERIES CODE CARDS

Complete Deck of 120 Cards

HPC Deck120

Deck - 120 Code Cards

**For current pricing, call your Fairway Representative today!**

**Dallas 800.776.3247 • Houston 800.767.3247 • Austin 877.309.6300 • Nashville 800.815.3247**



## THE AUTOMATE®

### FULLY AUTOMATIC KEY DUPLICATOR

Completely automatic action allows for total hands-free operation. The entire cutting cycle takes on 20 seconds. 4-way jaws allow it to cut a wide variety of keys. Spring loaded carriage assures consistent duplication. New expanded range of travel allows for the cutting of longer automotive keys. Cuts accurately and effortlessly. 120VAC, 1/6 HP, 3.7 amps. Weight: 32 lbs.

Machine Size: 12"W x 16" D x 11"H

Bench Size: 19"W x 16"D.

Cutter supplied: CW-42HQT

HPC 6666HQT Key Machine Automatic TS Cutter



**6666HQT**

## HPC 1200CMB CALIBRATION KIT

Easy to use kit is for all Blitz and 1200CM Code Machines. Designed to quickly and accurately diagnose machine calibration. If it is out of calibration, the kit can be used to calibrate your machine with just a few simple steps or determine whether factory service is needed. Helps to eliminate unnecessary downtime.

HPC CMBCK 1200CMB Calibration Kit



**CMBCK**



## 1200PCH PUNCH MACHINE

### EXTREMELY ACCURATE AND COMPLETELY PORTABLE.

Works on the same principle as the 1200CMB, making it the most versatile punch machine on the market. Extremely accurate and completely portable. Depth and space adjustments are not required in changing from one manufacturer to another. Complete with 83 code cards.

Punches Supplied: PCH-1011 & PCH-14

Machine Size: 9" wide x 12" deep x 6 1/4" High

Bench Size: 9" wide x 12" deep; Weight: 13 lbs.

### Accessories Included:

- 79 code cards and 4 micrometer cards.
- Carrying Case
- HPC Depth & Spacing Book.
- Wrenches
- Allen Wrench
- Manual

HPC 1200PCH Punch Machine

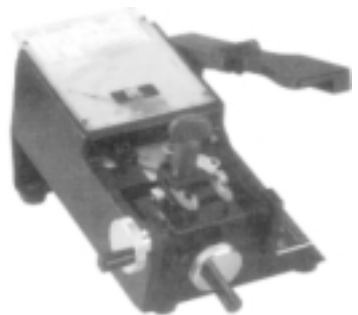



## The blue shark™ THE World's first touch screen key machine

Stand-alone **H**and **A**ctivated **R**obotic **K**eymachine

HPC's Blue SHARK™ is the first of it's kind to utilize touch screen technology for key origination, duplication and code retrieval.

- No computer needed! Easy system software update.
- Fully loaded with HPC's complete CodeSource™ database, including Vehicle, Padlock and Lockshop codes.
- Search DSD information by DSD Number or Manufacturer Name in the database of over 800 manufacturer specifications.
- User can search for codes by Manufacturer (with or without code), Code alone or Key Blank.
- Decoder reads depths of a cut key and displays the information on-screen. From there, a new blank can be inserted and cut to the same or an adjusted bitting.
- The Electronic Touch-Off allows users to cut double-sided automotive keys accurately by code.
- Electronic safety tip and shoulder gauges prevent you from cutting keys if the gauges are up.
- 4-way jaws enable the Blue SHARK™ to hold the greatest number of different blanks.
- Accommodates up to 18 spaces. Allows for the creation of 18-space Medeco® (two cuts per space) used in Medeco® master key systems.
- On-screen help file will take users step-by-step through all aspects of the machine.



## THE CODEMAX™

### THE ORIGINAL COMPUTERIZED CODE MACHINE

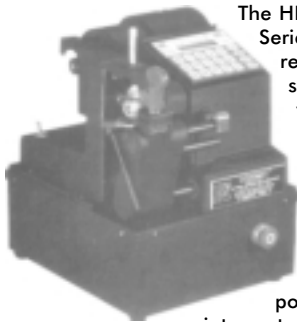

The HPC Codemax™ is the ultimate code machine! HPC took the 1200 Series Code Machine to the next level. Code key generation and reproduction are done automatically and accurately using machine stored manufacturers' dimensions. Codemax™ comes with five cutter wheels (CW-1011, CW-14MC, CW-9OMC, CW-20FM and CW-47MC), which allow it to cut the majority of keys available worldwide. Plus, Codemax™ performs automatic widening of cuts when necessary. With the optional Medeco® cutter (CW1012) and jaw (MJ-1), Codemax™ is ready to cut Medeco® brand keys, including Biaxial™. HPC currently produces four software programs to take advantage of Codemax's power. These programs allow Codemax™ to receive up to 250 keys in as little as 5 seconds. Codemax™ also employs a powerful feature called Job Interruption. This feature allows you to

interrupt a downloaded master keying job enabling Codemax™ to originate a code key and then return automatically to the master keying job. This powerful feature can save long setup times between code key and master keying jobs.

#### Accessories Include:

- Horseshoe Tip Stop
- Cutter/Adjustment Wrench
- Depth & Spacing Book
- Manual

HPC 1200MAX Codemax Computerized Codemach

Medeco® is a registered trademark of  
Medeco Security Locks.

**For current pricing, call your Fairway Representative today!**

**Dallas 800.776.3247 • Houston 800.767.3247 • Austin 877.309.6300 • Nashville 800.815.3247**



## CODESOURCE™

### THE ULTIMATE CODE RETRIEVAL PROGRAM

HPC's CodeSource™ is the most comprehensive, user-friendly code retrieval program on the market today! It has a database of well over 2 million codes that can be accessed quickly and easily. The Windows® operating system allows for quick maneuvering through the program with the point and click method or by clearly marked "hot keys".

CodeSource™ makes looking up a code completely effortless. There is no need to have extensive computer knowledge to run the program, simply follow the instructions on the screen. If you have questions, on-screen help is available at the touch of a button.

CodeSource™ allows you to search for a code in a variety of ways: by code number, 1200CMB and Punch™ code card numbers, manufacturer name or key blank number. With any or all of this information, the system will find the code that you need. The easiest way to find a code is by using the "Find Series" button. Just click on the "Find Series" button; this opens a window allowing you to enter your information. The more information that you know about the code, the easier it will be to find your code. The program will then search the entire database for the correct series.

CodeSource™ also allows you to search by biting or even partial biting. By simply pressing the "Find by Biting" button, the program will search the selected code series for a code with that particular biting. CodeSource™ will then display the code numbers and bittings that match the information you requested.

If you already know which code series you need, you may use one of the three category buttons listed on the screen (Lockshop, Padlock or Vehicle) to locate it. By pressing the button of your choice, a listing of all the code series in that category will be displayed. Highlight the appropriate series and then press the "Open Series" button. This opens up a window for you to enter the code you need. CodeSource™ then searches within the given code series to find the correct code specification screen.

The code specification window display the correct 1200CMB and Punch™ code card numbers, CodeMax™ DSD number, complete micrometer measurements, multiple key blank choices, cutter and punch numbers, correct jaw, graphic of the keyway and all pertinent information about the specific code series. From this screen you may download codes directly to you CodeMax™ or print out the screen. Clicking on the "Notes" button displays important information on your selected code and the code series, as well as providing you with space for your own notes. If the "Notes" button

is blinking, that means there is vital code series information that you need to read. Another feature of CodeSource™ allows you to view a graphic representation of the cut key. Click on the key magnification icon and a window with the key illustration appears.

Additional features allow you to enter new code series and to interact simultaneously with HPC's KeyChoice™. This allows for complete code series and key blank management.

CodeSource™ is available complete or in sections, in either CD format or 3 1/2" diskettes. You can purchase Locksmith Codes only (CSLS), Padlock Codes only (CSPL), Vehicle Codes only (CSVH), or CodeSource™ complete version (CS) that contains all the information from all 3 sections.

#### Minimum System Requirements:

- IBM Compatible Computer
- 486 Microprocessor
- 4MB Internal Memory (RAM)
- 25MB Hard Disk Space
- Microsoft Windows® 3.1
- VGA Monitor



#### Features:

- Instant access to well over 2 million codes
- Able to search by code, manufacturer, code card number or key blank number
- Able to search by biting or partial biting
- Displays Blitz™ and Punch Machine™ code card numbers
- Displays CodeMax™ DSD number
- Displays micrometer measurements in inches or millimeters
- Displays multiple key blank choices
- Displays correct cutter and punch number
- Displays correct jaw
- Displays graphic or keyway
- Displays illustration of cut key
- Displays information on manufacturers specifications
- Displays special information on specific code series
- Allows user to add notes to any code series
- Allows entry of custom code series
- Able to print out all code specification screens
- Immediate access to on-screen help function
- Able to interface with HPC KeyChoice™
- Fully compatible with HPC CodeMax™
- CodeSource™ can be installed on an individual PC or on a network server
- Timely updates
- Knowledgeable and friendly technical support



## KEYTRAIL™

### FOR COMPLETE MANAGEMENT OF KEYS, PERSONNEL AND LOCATIONS

The KEYS window displays a list of the keys that open the doors.

The LOCATIONS window displays a list of the doors that the keys open.

The PERSONNEL window displays a list of the people holding the keys.

Minimum Requirements:  
 IBM Compatible Computer  
 386 Microprocessor  
 4MB Internal Memory (RAM)  
 5MB Hard Disk Space  
 Microsoft Windows® 3.1  
 VGA Monitor

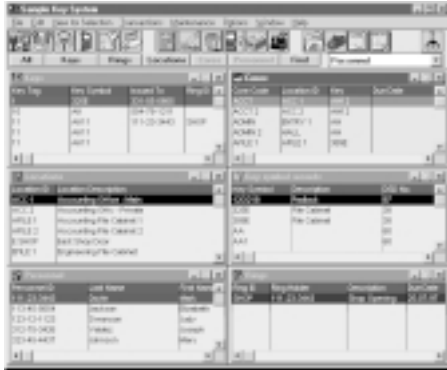

The CORES window lets you keep track of all of your cores, cylinders, and locks whether they are installed or in stock.

The KEY SYMBOLS window displays the biting, depth, and spacing information. Separating key Symbols from Keys and Core Allows people to view or loan out keys without having access to vital duplication information.

The RINGS window enables you to group keys together. Once together they can be moved and assigned as one.

**KeyTrail™ allows for the complete management of keys, the doors they open, and the people that hold them, all from one screen.**

- KeyTrail™ utilizes "drag & drop" technology to move one item to another. For example, to assign a key to an employee, just click on the key and drag it to the employee.
- KeyTrail™ is simple to use. You are provided with easy to understand icons, drop down menus, keyboard shortcuts, as well as a comprehensive Help file.
- KeyTrail™ has a very flexible security feature. The system administrator can set up an unlimited number of security profiles for other people who will be managing the system. Plus KeyTrail™ provides audit trails that track all transactions.
- KeyTrail™ generates optional work orders to track cylinder installation and key duplication.
- KeyTrail™ supports Interchangeable Core (IC) systems and can interface with HPC's MasterKing™ and CodeMax™ to make an all encompassing key producing/tracking package.
- Information can be imported or exported in either tab delimited or comma delimited format.
- KeyTrail™ can be installed on an individual PC or on a network server.
- Knowledgeable and Friendly Technical Support.



HPC KTCD KeyTrail - 3 1/2" format

KeyTrail™ has a very flexible security feature. It allows you to set up one or many system administrators. In turn, they can set up an unlimited number of security profiles to limit or give unlimited access to users on an individual basis. This will allow some people to only have the ability to view records, while giving others the ability to loan out keys without access to duplicating information in "Key Symbols." KeyTrail™ also provides a complete audit trail that tracks all transactions. Each window has a maintenance screen that gives you the ability to SEARCH through your list of records. In addition, you can ADD new records and UPDATE or DELETE existing records.

KeyTrail™ provides numerous reports on Keys, Key Symbols, Rings, Locations, Cores, and Personnel including: Personnel and the Keys They Hold; Keys and the Locations They Open; Locations and the Personnel That Have Access to Them; Lost Key Report and Overdue Key Report; Audit Trail; Orders for Key Issuance. KeyTrail™ generates optional work orders to track: Cylinder and Lock Installation and Removal; Key Duplication; Issuing and Returning of Keys and Rings.

**KeyTrail's tool bar at the top of the main screen simplifies your work.**



These buttons allow you to quickly open or close specific windows

- Add a New Record
- Edit Existing Records
- Delete Records
- Return Keys or Rings
- Cut Keys
- Print Record Information
- Create New System
- View the History Log
- Create/Edit Work Orders
- Print Reports
- Get Help

**For current pricing, call your Fairway Representative today!**

**Dallas 800.776.3247 • Houston 800.767.3247 • Austin 877.309.6300 • Nashville 800.815.3247**



## MASTERKING™

### FOR DEVELOPMENT OF SUPERIOR MASTER KEYING SYSTEMS

MasterKing™ gives you the ability to accept or change manufacturers' specifications and view all of your bitting possibilities before you start entering any information. MasterKing™ allows you to create new systems in List or Page format, or manually enter an existing system.

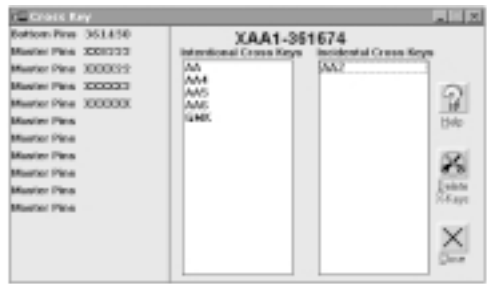

MasterKing™ allows you to create systems from 1 to 5 levels using the Total Position Progression method, or 2 level systems using the Rotating Constants method. From this screen you are able to customize your progression sequence and check theoretical and actual bittings before you generate your system.

MasterKing™ supports cross keying and helps you keep your systems secure by listing both intentional and incidental cross keys.

#### MasterKing™

HPC MKCD	Masterkeying Software
HPC MKICCD	Software Masterkeying IC



In LIST format, enter the number of levels and the top Master Key (TMK) bitting. Choose which chambers should progress at each level and their sequence. View the total number of theoretical bittings and after clicking "Compute Actual" you will see the total number of actual bittings.



In PAGE format, enter the TMK bitting and progression sequence. Then with the press of just one button, you have created a master key system!

MasterKing™ creates superior master keying systems. Enter some basic information and MasterKing™ will generate you systems quickly and easily. MasterKing™ eliminates transposed or repeated numbers as well as uncuttable keys. Manually writing master key systems can be very time consuming and error prone. Use MasterKing™ to produce accurate systems in minutes instead of days.

- Contains a database of more than 100 lock types and more than 50 manufacturers
- Allows entry and new manufacturers through Custom Hardware feature
- Able to generate 1 to 5 levels in LIST format
- Displays Change Keys, Block Master, Row Masters, Column Masters, Page Masters and the TMK in PAGE format
- Supports cross-keying
- Supports Rotating Constants
- Handles locks containing 4, 5, 6, 7 or 8 chambers
- Handles Interchangeable Core (IC) systems
- Allows manual entry of existing systems
- Allows entry of descriptions for each key symbol
- Allows customized progression sequence
- Allows printing of bittings, pinnings and pin count
- Automatic manufacturer specification fill-in with easy editing capacity
- Optional password for added security
- Immediate access to on-screen help function and on-line tutorial
- Able to interface with HPC's KeyTrail™
- Fully compatible with HPC's CodeMax™
- Timely updates
- Knowledgeable and friendly technical support





## 1200 SERIES CUTTERS

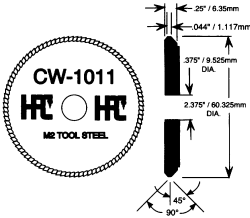

**CW1011**  
90° angle, small cylinder cutter

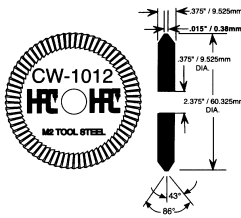

**CW1012**  
Optional milling cutter has angle & pin seat for cutting Medeco® High Security

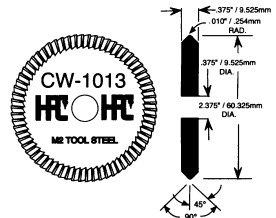

**CW1013**  
Only available cutter with exact angle of cut and full "V" pin set for Emhart High Security

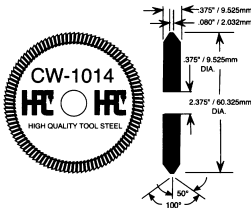

**CW1014**  
This specially designed cutter has .080"/2.03mm flat for one step cutting of Kwikset, Weslock & Weiser using original pins

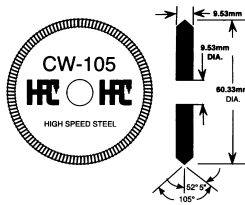

**CW105**  
105° angle, double angle cutter for ASSA

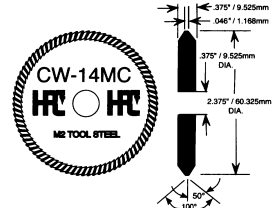

**CW14MC**  
100° angle, standard large cylinder cutter

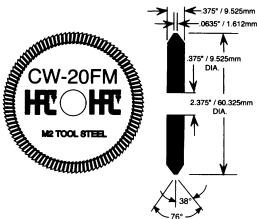

**CW20FM**  
76° angle, double angle, flat mill tooth for Sargent

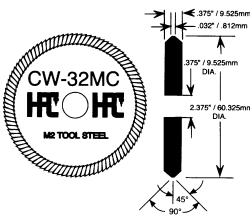

**CW32MC**  
Specially designed 90° angle, tool steel cutter for ASSA keys with .032"/0.81mm flat

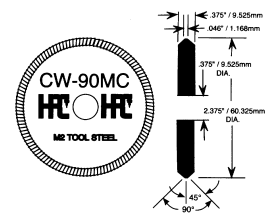

**CW90MC**  
90° angle, large cylinder cutter for shallow & deep cuts in adjacent positions. For Best, Falcon, Eagle, Arrow, Kaba and IC core.

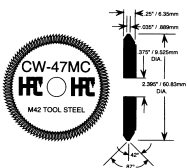

**CW47MC**  
87° angle, tool cutter for some automotive

For current pricing, call your Fairway Representative today!

Dallas 800.776.3247 • Houston 800.767.3247 • Austin 877.309.6300 • Nashville 800.815.3247



## SPEEDEX® CUTTERS

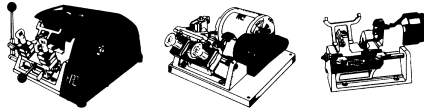

### Single Angle Cutters

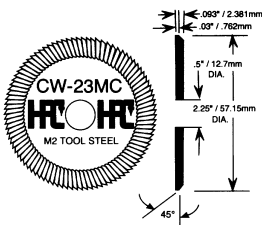

#### CW23MC\*

Tool steel cutter with teeth on both sides is ideal for finishing cut. Standard replacement cutter for 9160MC and 9180MC.

*\*NOTE: Slotter cutting is not recommended for 9120 machines due to their greater rpm speeds which will cause excessive wear on cutters*

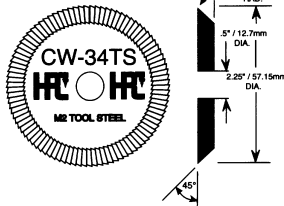

#### CW34TS

Precision milled tool steel cutter (requires optional tracer #9120-13 for 9160MC and 9180MC).

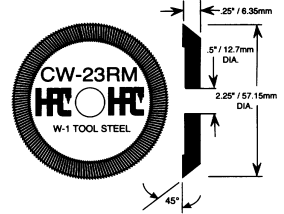

#### CW23RM

Standard grade W1 tool steel cutter. Standard replacement cutter for 9120RM.

## DEBURRING BRUSHES

### HPC SOFTIE™ BRUSH

The only key machine brush made of Tylon-X. The carbide impregnated brush deburrs faster, smoother, and lasts 6 times longer than wire. No more flying wire strands and brush flaring.

HPC TYX3 3" Softie Brush



## REPLACEMENT WING NUT

This sturdy blue wing nut is virtually indestructible! Fits all HPC 1200 Series, Speedex® Series, Trace-A-Key®, and Automate™.

HPC SNK3 1200CM Wing Nut





## KEY MACHINES

### MANUAL

Machine is a light-weight, portable and low cost machine. Duplicates cylinder and automotive keys, single and double sided. Precision made vise jaws are not reversible, adapters are needed. Ideal as a 2<sup>nd</sup> machine. Ship. Wt: 12 lbs. 11" w, 5" d, 8" ht.



**027A**

ILC027A-110VAC Key Machine, Mini Manual

### MANUAL

Accurate, easy to use & economical. Titanium nitride cutter is standard. Duplicates cylinder keys, single & double sided. Wide carriage permits cutting of large bow keys. Four-way reversible vise jaws hold single & double sided keys without adapters. Chip shield provided with durable cover to meet OSHA & CSA requirements. 110 volt motor. Shipping wt: 39 lbs. Dim: 15"W x 14.5"D x 9" Ht.



**045**

ILC045-110VAC Key Machine, Manual

### DUAL VOLTAGE MANUAL

This key duplicating machine can be used in your van or on the job with no extra converter or generator to buy. All electrical connections are built into the machine. Four-way reversible jaws hold standard, wide, double sided and Schlage keys — without adapters. Carrying case included. Meets OSHA and CSA standards. Dim: 11" w, 14" d, 11" ht. Ship wt: 39 lbs.



**023**

ILC 023-110V Key Machine, Manual

### BRAVO BRUSH

ILC D301840ZZ Brush for Bravo Key Machine

### BRAVO CUTTER

ILC D400875ZZ Cutter for Bravo Key Machine



**008**

### MINI-MITE

Power packed portable with all the "Shop" features you want. Reversible vises to cut single and double sided keys. High speed motor.

Equipped with 23RF cutter. Four sided key rake for deburring keys. Hood covers moving parts and meets OSHA requirements. Carriage accepts all size key blanks including Hotel keys. Gauge fork aligns key blanks accurately. Wt: 10 lbs.

ILC008-110VAC Key Machine 110 Volt



**009**

### TUBULAR KEY MACHINE

Perfect addition to your shop or van. Easy to set up & operate. Dupli-

cates accurately in seconds. Unique, positive indexing feature assures fast accurate location of each cut. Shipping wt: 8 lbs.

ILC009-110VAC Key Machine



**017**

### AUTOMATIC

Designed to automatically duplicate all types of cylinder keys, including large bow keys, at touch of a button. Cycle time is approx. 14 seconds, and

a titanium nitride coated cutter is standard equipment. 110 volt motor. Ship wt: 40 lbs. Dim: 11"W x 14" D x 9" Ht.

ILC 017 Key Machine, Automatic

## ACCESSORIES

### SOFT TOUCH BRUSHES

ILC 814-00-51 Soft Touch Brush 3"

ILC 815-00-51 Soft Touch Brush 6"

ILC 816-00-51 Fiber Brush 4"

### WIRE BRUSH

ILC 12-10A Wire Brush 3"

For current pricing, call your Fairway Representative today!

Dallas 800.776.3247 • Houston 800.767.3247 • Austin 877.309.6300 • Nashville 800.815.3247

## NUMBERALL

### **Mono Wheel**

### **Automatic Character Spacing**

Designed for the purpose of impressing letters and numbers in a variety metal plates, parts and keys. The dials are made of special high grade tool steel with characters carefully engraved to make clear cut impressions with uniform depth.

### **Features:**

- › 42 characters - a through z, 1 through 0 and ' . - & /
- › Characters are 1/8" in height
- › Standard Table is 6 x 8 1/2"
- › Plates up to 5" wide by unlimited height can be stamped to within 4 1/4" from the top of plate
- › Depth of impression is adjustable
- › No experience is necessary to operate press

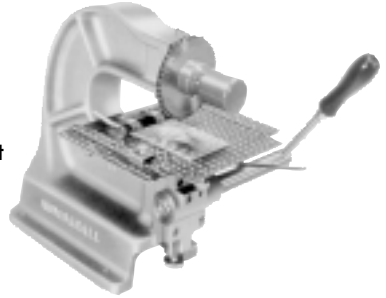

## PRO-LOK CODE KEY MACHINE

### **A New Depth Code System**

At the heart of the new depth coding system is the KeyMaster Code Wheel™, a precision machined rotary ball bearing mechanism that reduces maintenance and errors. By "clicking" the code wheel to the appropriate depth code number, you'll cut keys faster, easier and maintain tighter specifications on all key cuts.

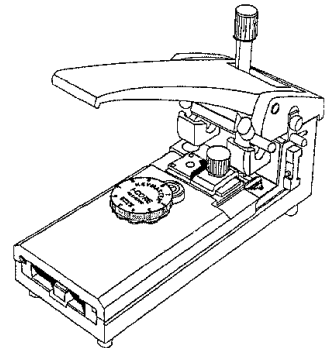

PLK Schlage Punch	BP201-SC
PLK Falcon IC Punch	BP201-IC